

INTOREX



**woodworking
machinery**

TMC 1500/3000 Specifications

Max. length to be machined	1500 / 3000 mm
Max. diameter to be machined	300 mm
Automatic feeding up to	Sq. 150 mm
Manual feeding up to	Sq. 210 mm
Total axes	9 / 10
Axes stroke	
X axis	2100 / 3900 mm
Y, Z axis	460 mm
U, V, W, P axis	360 mm
A axis	∞
B axis	90°
Headstock (A axis)	22,2 Kw
Rotation speed	0 - 1.500 rpm
Turning head (U axis)	11 KW
Rotation speed	1.000 - 4.500 rpm
Shaping head (V axis)	11 KW
Rotation speed	1.000 - 6.000 rpm
Sanding head flat (W axis)	2,2 KW
Interchangeable Rotation speed	3.000 rpm
Sanding head turned (W axis)	0,5 KW
interchangeable Rotation speed	3.000 rpm
Electro spindle (B axis)	12 KW
Rotation speed	22.000 rpm
Sanding head turned (P axis)	0,5 Kw
Optional Rotation Speed	3.000 rpm
Type of tool holders	HSK F63
Type of tool changer	Rotary (10 positions)
Total power installed	70 Kw
Weight of the machine	4.700 kg
Dimensions	5200x4200x3400(h)mm 6800x5000x3400(h)mm

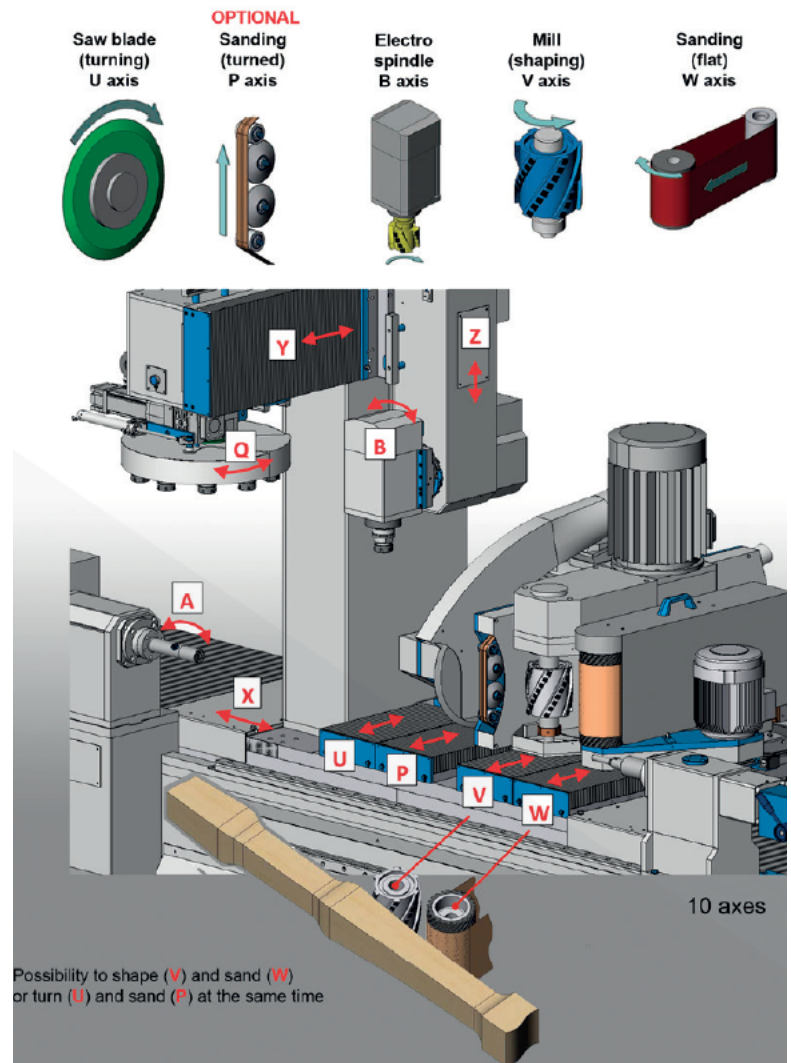

INTOREX reserves the right to modify the technical features of its products without prior notice



MACHINERY INC.

*SERVING the CAROLINAS
and VIRGINIA
SINCE 1953*